

## Sewing tips: Apron

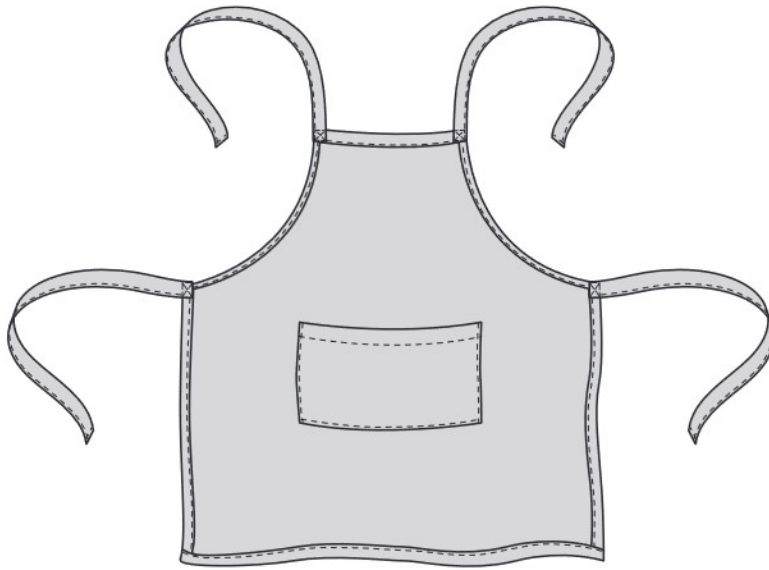

Making your own personal apron is easy and fun. At IKEA we have everything you need, from a wide range of fabrics in different colours and patterns to sewing accessories.

**Skill level:** Medium

**Tools:** Pattern paper, ruler, pencil, measuring tape, scissors, pins, sewing machine, sewing thread and an iron.

**Fabric:** 100 cm in length and minimum 140 cm in width. All IKEA fabrics are 150 cm in width.

**Good to know:** If you are using a cotton fabric, please bear in mind when you measure your fabric that cotton can shrink up to 4% when washed.



## Follow these simple steps:

### Pattern making and cutting the fabric

1. Draw a pattern for the apron using the sizes shown here. Fold the fabric double, place the pattern pieces on the fabric and cut out the parts.

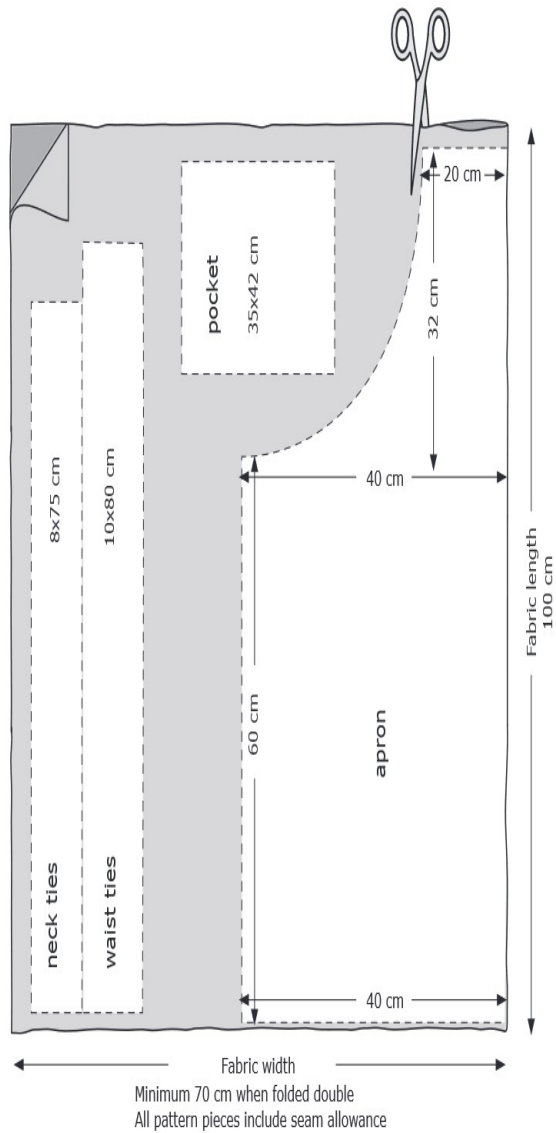

2

### The tie strings

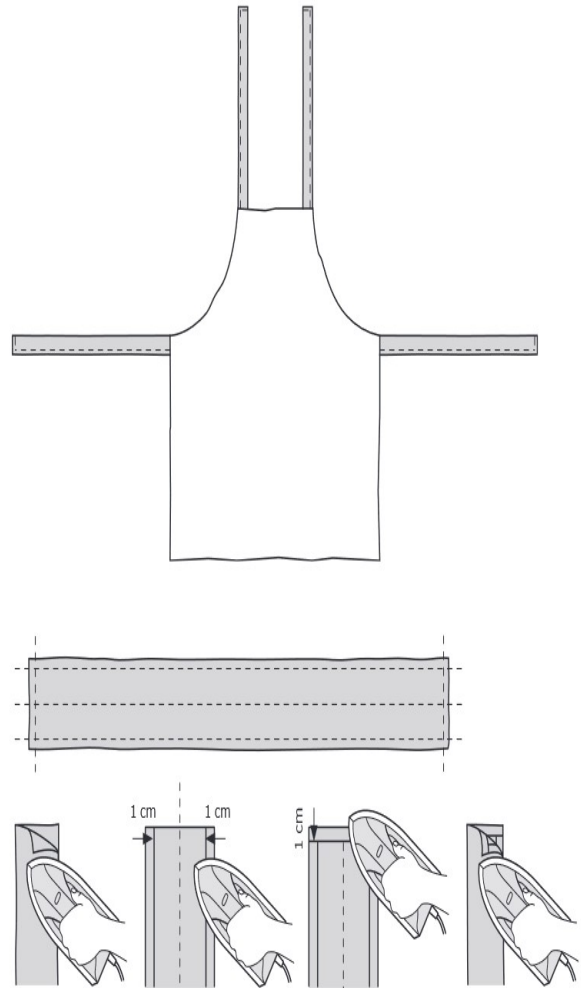

2. Fold and press the tie strings in half lengthwise. Then open them up and press each side 1 cm towards the centre. Fold the fabric again down the middle lengthwise and press with an iron.



3. Sew a top-stitch 0.5 cm from the folded edge. Repeat to make the other tie string.

3

## The apron

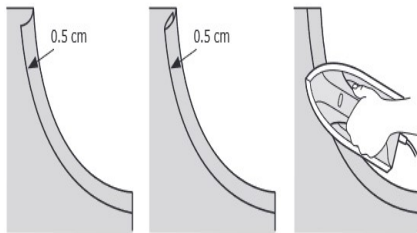
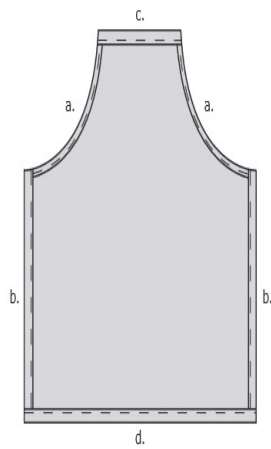

4. Fold and press each curved side of the apron (a) 0.5 cm and then another 0.5 cm towards the centre and press with an iron.

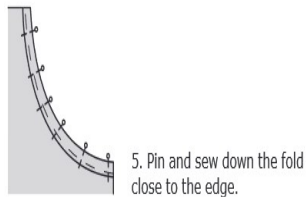

5. Pin and sew down the fold close to the edge.

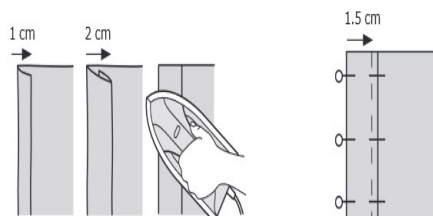

6. Fold and press all of the other sides (b,c,d) of the apron 1 cm and then another 2 cm towards the centre of the apron.

7. Pin and sew them down 1.5 cm from the edge.

## Attaching the tie strings to the apron

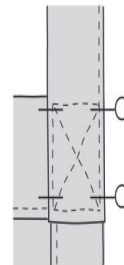
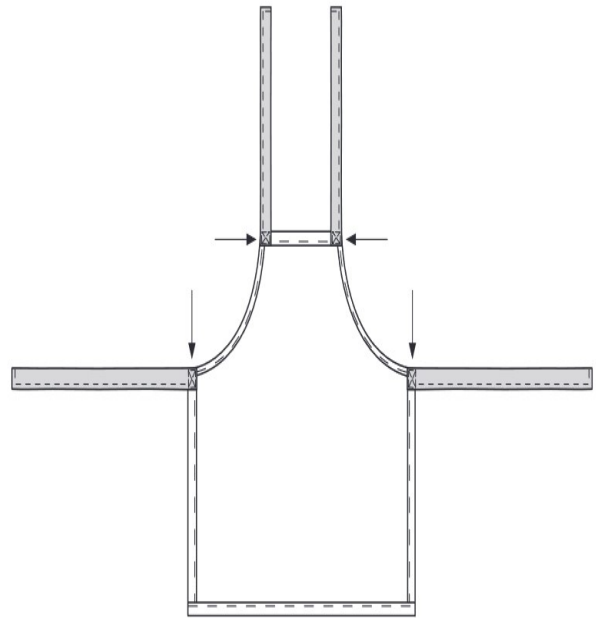

8. Pin the short tie strings to the top corners of the apron. Sew them to the reverse side of the fabric by sewing a square with a diagonal cross inside.

Pin the long tie strings to each side of the apron, using the same technique as for the short tie strings.

## The pocket

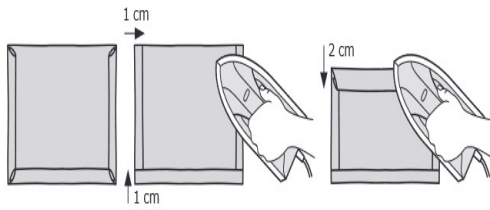

9. Fold and press each of the sides and the bottom of the pocket 1 cm towards the centre. Fold and press the top side of the pocket 1 cm and then another 2 cm.

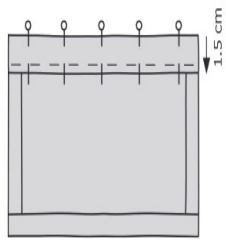

10. Pin and sew the folded top of the pocket down 1.5 cm from the edge.

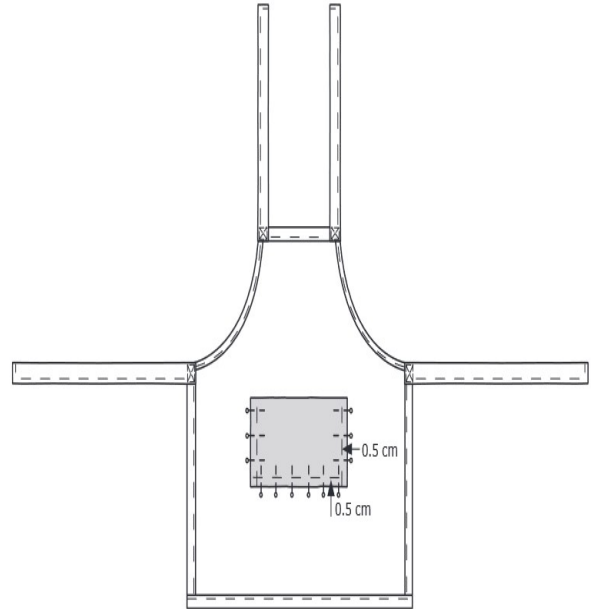

12. Pin the pocket onto the apron. Sew around the edge of the pocket 0.5 cm from the edge. Make sure to leave the top open.

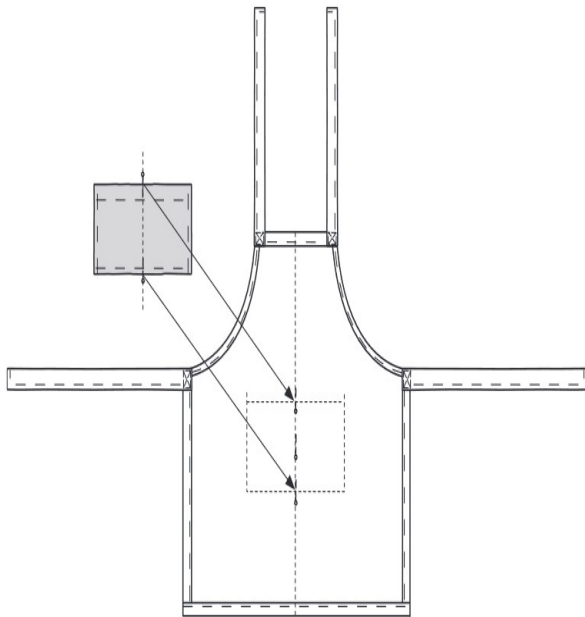

11. Find the centre of the pocket by folding it in half across the width. Mark the fold with pins. Repeat with the apron. Pin the pocket onto the apron lining up the fold lines marking the centres.

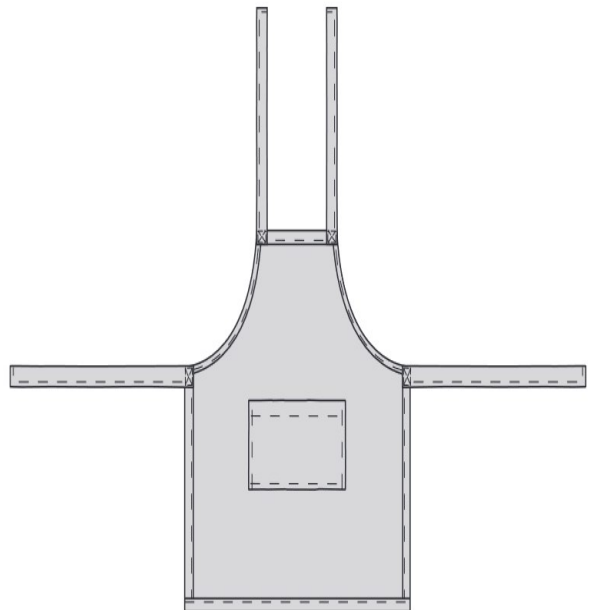

Now your apron is ready to wear. Enjoy your creation!

